



Imaging Cannula Implantation & Microscope Installation For SFMB

Application Note

Version 1.4.2

Contents

1	Microscope Model Specifications	3
1.1	Model-S	4
1.2	Model-L	5
2	Implantation of the Imaging Cannula	8
2.1	Cannula Removal and Installation	8
2.2	Fluorescence Microscope Holder Installation	11
2.3	Animal Surgical Preparation	12
2.4	Protrusion Adjustment Ring Installation	13
2.5	Cannula Installation	13
2.6	Securing the Cannula on the Skull	16
2.7	Animal Clamping and Unclamping	16
2.8	Tissue Healing and Training of the Animal (3 weeks or more)	18
3	Imaging Sessions	19
4	Handling & Cleaning	21
4.1	Important handling information	21
4.2	Cleaning optics	21
4.3	Imaging cannulas reuse	21
5	Support	22
5.1	Contact us	22

Microscope Model Specifications

The depth of the region-of-interest determines the choice of microscope body and imaging cannula. For brain regions up to 8.4 mm in depth, the *Model-L Cannula* is implanted within the brain, while the *Model-L Microscope* allows imagery of brain tissue at these locations. The *Model-S Microscope* is preferred for surface observation as it is optimized for a field of view between 0 and 150 μm below the brain surface (Fig. 1.1).



Figure 1.1: Single-color Miniature Fluorescence Microscope Model-S (left) and Model-L (right)

1.1 Model-S

For a model-S, the field of view obtained is $700\ \mu\text{m} \times 700\ \mu\text{m}$ (Fig. 1.2) and the depth of field (focus range) is $50\ \mu\text{m}$ ($\pm 25\ \mu\text{m}$) (Fig. 1.3). The working distance of $1.1\ \text{mm}$ is defined as the distance from the bottom of the metal part of the cannula to the focal plane. This allows a penetration depth of $0\text{--}150\ \mu\text{m}$. For the model-S cannula, a single protrusion adjustment ring (height of $4.5\ \text{mm}$) is required to observe the full range.

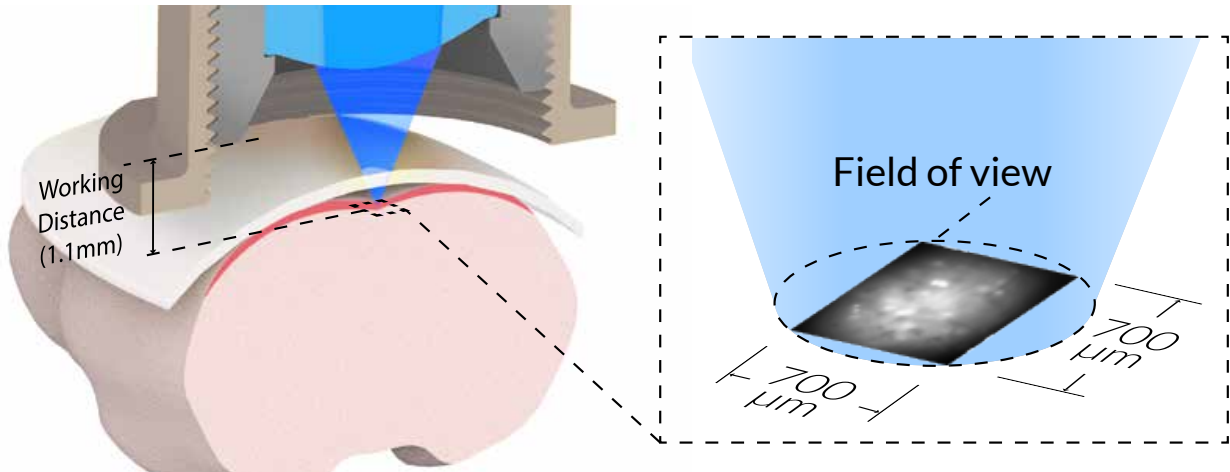

Figure 1.2: *Field of View Obtained by the Model-S Imaging Cannula*

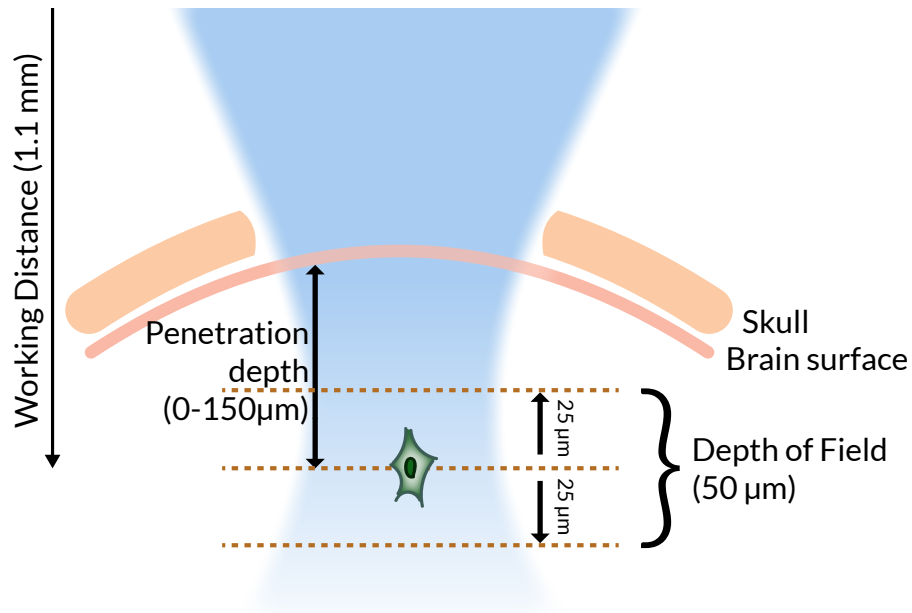

Figure 1.3: *Depth Range of the Model-S Imaging Cannula*

1.2 Model-L

For deeper brain regions, a gradient-index (GRIN) rod lens is needed to guide the image from inside of the brain to the microscope body objective. Depending on the depth of the region of interest, three types of imaging cannulas are available (D, V or E) with different lens lengths. Table 1.1 gives the range of penetration depths obtained with each cannula type. The penetration depth for this model is measured from the surface of the skull or the bottom of the protrusion ring to the region of interest.

Table 1.1: Range of Penetration Depth

Cannula type	Range of penetration depth d (mm) ¹
D	0 - 3.4
V	3.0 - 6.0
E	5.4 - 8.4

The working distance of our standard snap-in imaging cannulas model-L is 80 μm and represents the distance from the extremity of the relay lens to the focal plane (devices with different working distances are offered on request). It means that the microscope does not image immediately underneath the lens, and this working distance must be considered when calculating the required depth. The depth of field or focus range is 50 μm (Fig. 1.5). The field of view of the microscope model-L is 350 μm X 350 μm (Fig. 1.6).

To ensure that the cannula is well secured on the skull, the imaging cannula must be combined with a protrusion adjustment ring. To select the right adjustment ring, follow these steps (Fig. 1.4).

1. Measure the protrusion length (L) of the lens from the bottom of the metal part of the cannula to the extremity of the lens.
2. Determine at which depth in the brain you want to position the extremity of the lens. Add to this measure the thickness of the skull and the working distance of the rod lens (typically 80 μm). To ensure the protrusion adjustment ring will not be too low, it is recommended to add 100 μm more to this measure. You will obtain the distance (d) represented by the distance from the tip of the lens to the bottom of the protrusion adjustment ring.
3. The protrusion of the adjustment ring (p) is given by : $p = L - d$ and corresponds to a specific ring set (Table 1.2). Each ring set is identified by its height (h).
4. Place the selected ring on the cannula and adjust the position of the ring with a binocular microscope to obtain the required distance (d).

Table 1.2: Protrusion Adjustment Ring Model L Selection

Ring #	Height (h) of the ring (in mm)	Protrusion (p) of the ring (in mm)
1	2.0	0 - 1.5
2	2.7	0.7 - 2.2
3	3.4	1.4 - 3.0
4	4.2	2.2 - 3.7
5	4.9	2.9 - 4.4

¹Including a working distance of 80 μm

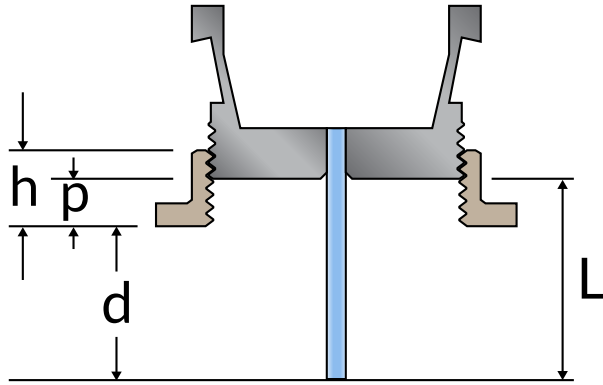

Figure 1.4: Protrusion Adjustment Ring Selection

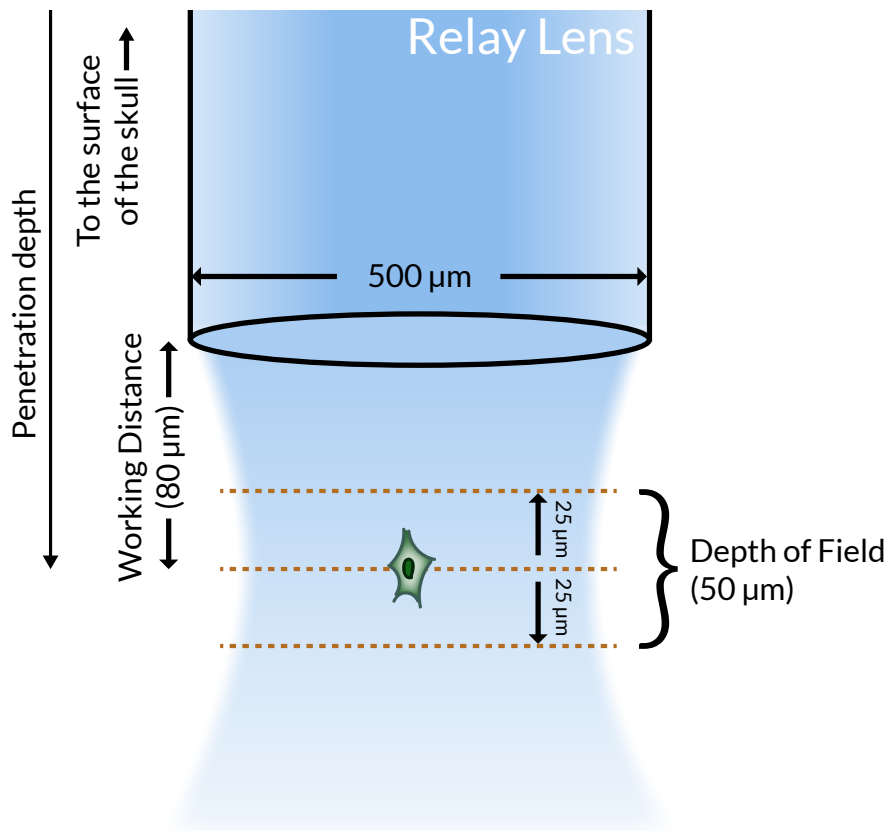

Figure 1.5: Depth Range of the Model-L Imaging Cannula

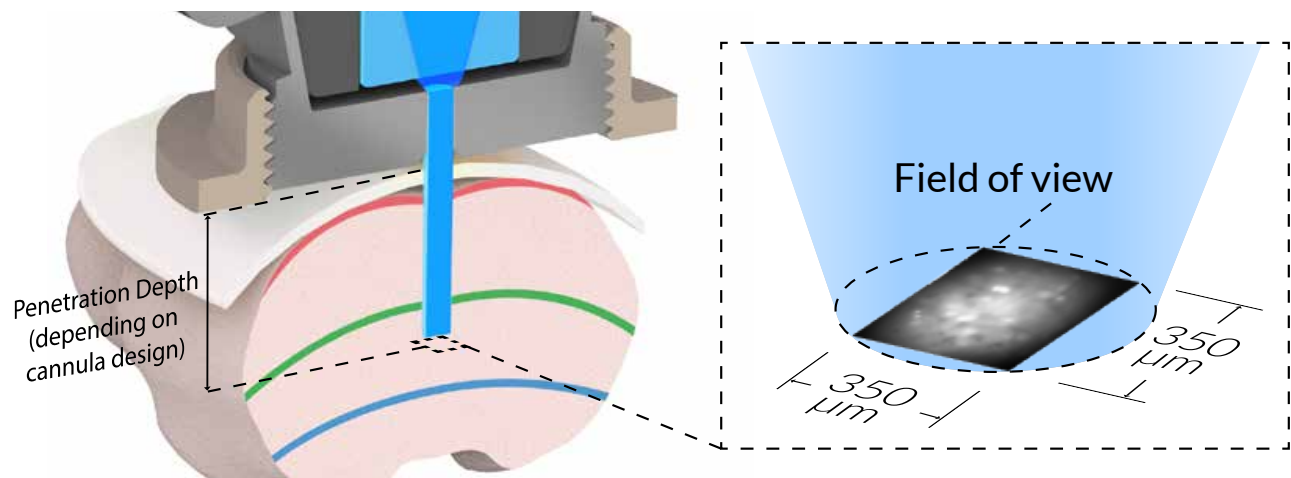
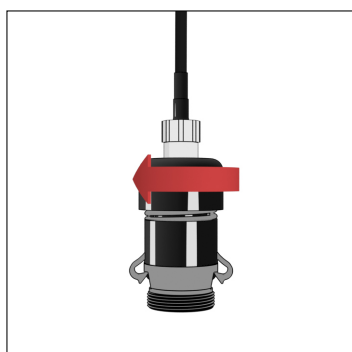

Figure 1.6: *Field of View Obtained by the Model-L Imaging Cannula*

Implantation of the Imaging Cannula

The following section describes the use and implantation of the *Single-color Miniaturized Fluorescence Microscope*. This section is also detailed in our [Instructional Video](#).

2.1 Cannula Removal and Installation



(a) Turn the barrel clockwise until you feel resistance then add 1/4 turn

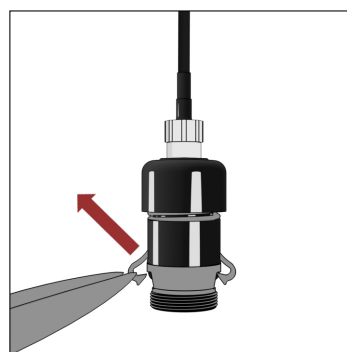

(b) Rotate the tip of the snapping tool inside the left clamp

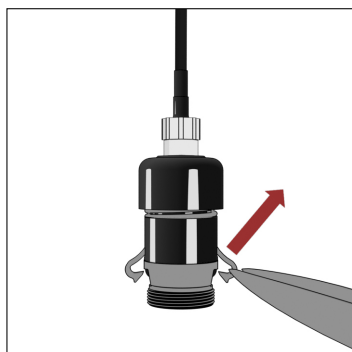

(c) Rotate the tip of the snapping tool inside the right clamp

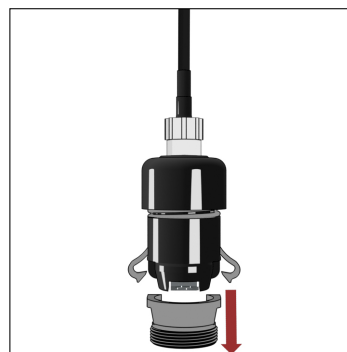

(d) Remove the protective cannula

Figure 2.1: Unclamping the Microscope Body Protective Cannula

The microscope body is delivered with a protective cannula that should be removed for the first use and reinstalled after each imaging session to protect the microscope. To remove the protective cannula and secure the imaging cannula on the microscope body, follow the procedure described in this section. Handle the microscope and cannula with care. The relay lens and objective are fragile and any stain or scratch can affect image quality. **Do not touch the surface of the lenses.**

1. Remove the **Protective Cannula** from the *Microscope Body* (Fig. 2.1). Any other microscope cannula can be removed in the same way. If the cannula is installed on an experimental subject, follow the instructions in section 2.6.
 - a) Use the microscope barrel to change the tightness of the latching mechanism. If the barrel is loose, turn the barrel clockwise until you feel resistance, then add 1/4 turn (Fig. 2.1a). **Never screw the barrel more than a half turn after the resistance point.** In the opposite direction, if you already feel resistance when turning the barrel clockwise, it means that the barrel is too tight. In this case, you need to turn the barrel counterclockwise to find the point at which it starts becomes loose, then rotate clockwise 1/4 turn.
 - b) Remove the left **Microscope Clamp** from the **Cannula Clamp Groove** (Fig. 2.1b) by rotating the *Snapping tool* inside the gap.
 - c) Remove the right **Microscope Clamp** from the **Cannula Clamp Groove** (Fig. 2.1c) by rotating the *Snapping tool* inside the gap.
 - d) Remove the **Protective Cannula** (Fig. 2.1d).
2. Secure the imaging cannula on the *Microscope Body* (Fig. 2.2). Any other microscope cannula can be installed in the same way. This method is valid when installing the microscope on an experimental subject.
 - a) Ensure the barrel is 1/4 turn clockwise past the resistance point, as it would be at the end of step 1. This ensures the clamps are loose.
 - b) Remove the **Input Protective Cap** from the *Imaging Cannula* (Fig. 2.2a).
 - c) Insert the imaging cannula onto the *Microscope Body* (Fig. 2.2b).
 - d) Clip the clamps into place (Fig. 2.2c).
 - e) Unscrew the barrel counterclockwise until it becomes loose (Fig. 2.2c and 2.2d). This ensures the clamps are tightly holding the cannula. It is very important to **never unscrew the barrel completely.**

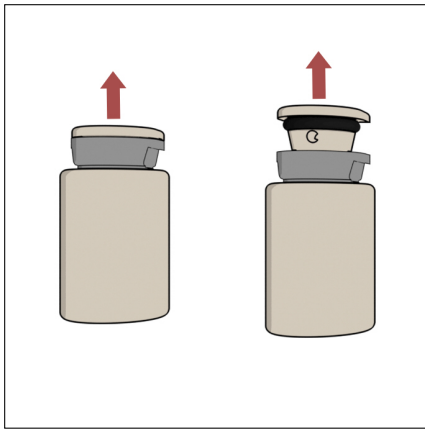

(a) Remove the protective cap of the imaging cannula

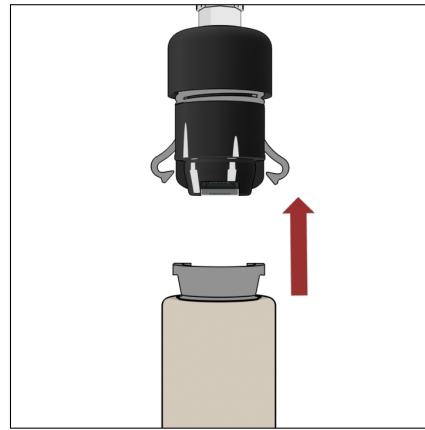

(b) Insert the imaging cannula on the microscope body

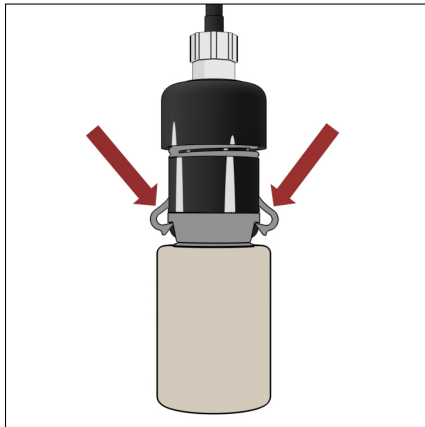

(c) Clip the clamps in place

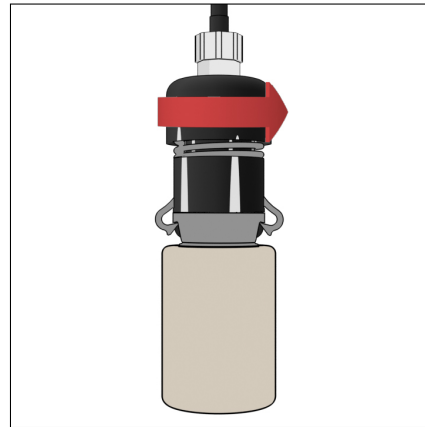

(d) Unscrew the barrel counterclockwise until it becomes loose

Figure 2.2: Securing the Imaging Cannula on the Microscope Body

2.2 Fluorescence Microscope Holder Installation

For the implantation of the cannula, the microscope can be secured on the *Fluorescence Microscope Holder (FMH)*. The holder allows imagery during the descent of the relay lens to the brain. Experiments not requiring a freely-moving animal can be done with this head-fixed configuration.

1. Remove the **Connector Caps** from the microscope **M3 Optical Connector** and the *Fluorescence Microscope Holder* ferrule (Fig. 2.3a).
2. Insert the ferrule into the **M3 Optical Connector** (Fig. 2.3b). Secure them in place by screwing the *Fluorescence Microscope Holder* extremity (Fig. 2.3c).
3. Install the *Fluorescence Microscope Holder* into a stereotaxic apparatus.
4. When ready for use, remove the **Output Protective Cap** from the cannula by unscrewing it (Fig. 2.3d). When using a type-L cannula, take great care to remove it in a straight motion so as not to touch or break the rod lens.
5. Before the implantation, remove the protective cap and start the acquisition system to check the quality of the image obtained by the lens. Make sure **not to touch the surface of the lens**. When the obtained image shows spots, there may be dust on the lens. Use a cotton swab to clean the tip of the lens with acetone or isopropyl alcohol. **Never dip the lens in acetone**. Close the acquisition system after the test.

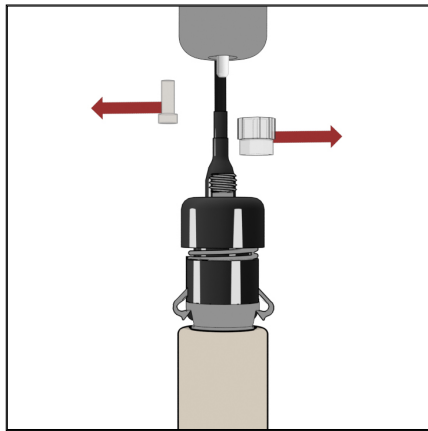

(a) Remove the protective caps from the microscope and FMH

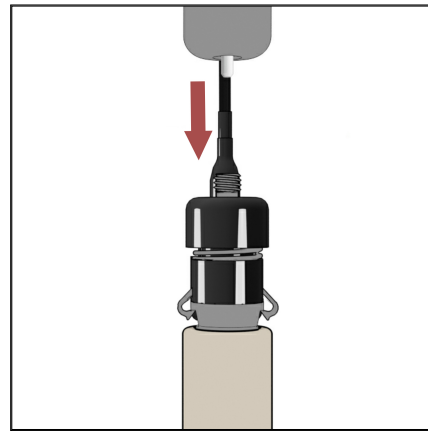

(b) Insert the FMH ferrule into the microscope M3 connector

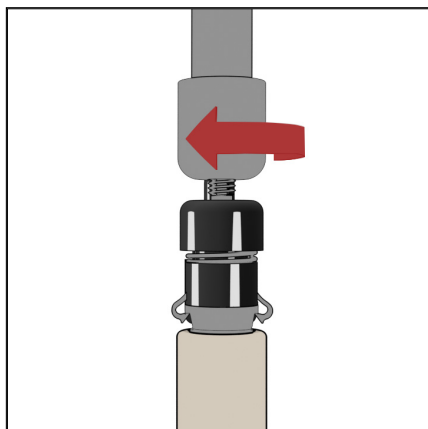

(c) Screw the FMH extremity onto the M3 connector

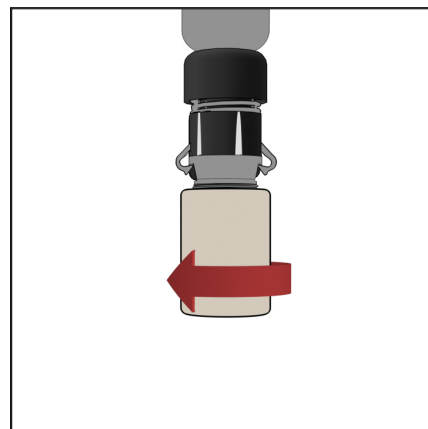

(d) Unscrew and remove the cannula output cap

Figure 2.3: Securing the Fluorescence Microscope Holder (FMH)

2.3 Animal Surgical Preparation

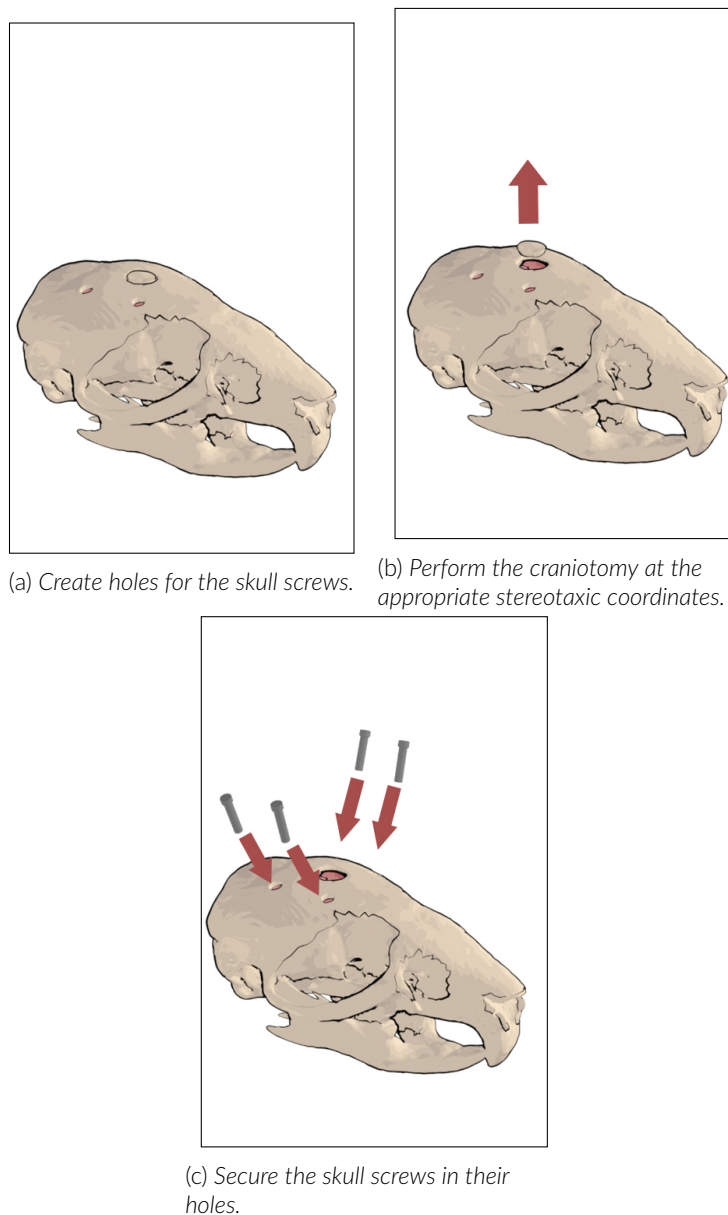

Figure 2.4: Surgical Preparation

Before implantation, the animal subject must be prepared. This includes the placement of **Skull Screws** to secure the cannula, and a craniotomy to allow observation of the brain.

1. Determine the stereotaxic coordinates for cannula implantation.
2. Drill holes to allow the placement of the skull screws (Fig. 2.4a)¹. This requires a distance of at least 5 mm from the center of the craniotomy to allow rotation of the *Protrusion Adjustment Ring*.
3. Perform the craniotomy (Fig. 2.4b). When using a type-L cannula, the hole must have a diameter larger than the rod lens diameter, 500 μm . When using a type-S cannula, the hole must have a diameter of at least 2 mm.
4. Place 4 supporting screws in the prepared holes around the craniotomy site (Fig. 2.4c).

¹Screws not provided with microscope.

2.4 Protrusion Adjustment Ring Installation

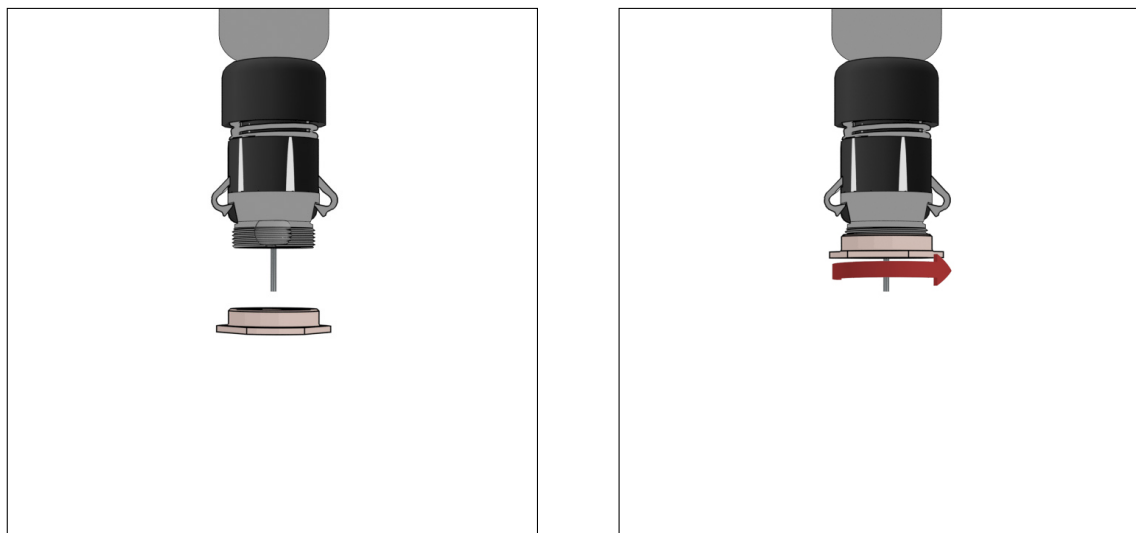

(a) Place glue drops into cannula thread.

(b) Thread the protrusion adjustment ring onto the cannula.

Figure 2.5: Protrusion Adjustment Ring Installation

To prepare for implantation, the *Protrusion Adjustment Ring* must first be installed. The ring is used to stabilize the system on the skull when the implanted cannula is at the appropriate depth. Its position is determined by the depth of the structure of interest relative to the top of the skull (see section 1.2).

1. Place a couple of drops of a slow drying glue (e.g. epoxy adhesive) to secure the ring to the metal thread of the imaging cannula².
 - **Be careful not to apply glue on the microscope body or the imaging lens.**
 - The slow drying will allow little adjustments during the implantation.
 - Each full rotation of the protrusion adjustment ring represents a vertical distance of 300 μm .
2. Attach the proper protrusion adjustment ring to the cannula at its approximate position. For type-L cannulas, place the *Protrusion Adjustment Ring* in a slow, vertical motion to avoid making contact with the rod lens.

Once the *Protrusion Adjustment Ring* is in place, the microscope can be moved above the animal subject.

2.5 Cannula Installation

2.5.1 Type-S Cannula Installation

When using a type-S cannula, no penetration is necessary as the lens does not enter the brain. The region must however be prepared for observation. The following sections shows a few recommended protocols for surface imagery.

1. Prepare the animal for observation. There are several methods possible to obtain optimal image quality. It should be noted that the type-S *Imaging Cannula* leaves a small air pocket between the brain and the objective lens. Dura exposed to air becomes opaque (white) over time, while brain mater can be damaged by air exposure.
 - The use of a **Cranial Window** is common. These thin, small-diameter glass windows are placed above the craniotomy opening, reducing the air exposure of the brain. The space between the window and the brain can also be filled with a biocompatible transparent medium, such as agarose.
 - The **Thin-skull Window Technique** involves progressive thinning of the animal subject's skull. This thinning allows light to be transmitted through the skull, thus allowing imagery without penetrating the skull itself.

²Glue not provided with microscope

- The **Side-prism Method** (Fig. 2.6) can be used in conjunction with a **Cranial Window**. A microprism is inserted into the surface areas of the brain, which allows the viewing of regions perpendicular to the normal focal plane.

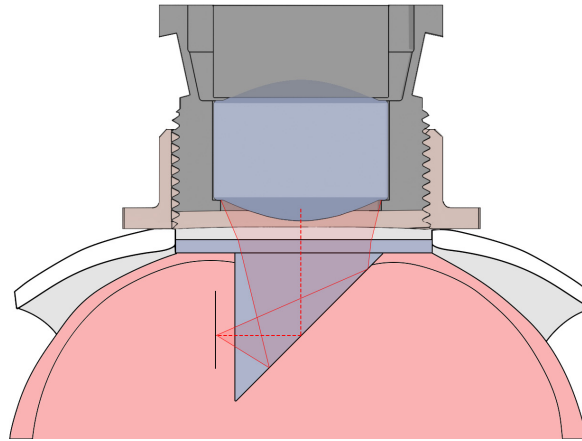

Figure 2.6: Side-prism Method

2. Connect the *Fluorescence Microscope Holder* to the illumination system.
3. Lower the microscope above the craniotomy hole.
 - The fluorescence microscope holder allows illumination during implantation.
 - If the cannula is installed when a sufficient viral expression has been reached, a diffuse fluorescence signal will confirm the positioning of the focal plane in the targeted area (e.g. injection site).
 - If the cannula is installed immediately after the viral injection, the fluorescence signal cannot be used to confirm the positioning of the focal plane in the targeted site.
4. When there is a significant gap between the *Protrusion Adjustment Ring* and the skull, the position can be adjusted.
 - Verify that the *Fluorescence Microscope Holder* is secure and that the microscope will not move if touched.
 - Slowly unscrew the *Protrusion Adjustment Ring* to bring it closer to the skull.

2.5.2 Type-L Cannula Installation

Setting the Depth Reference

When using a type-L cannula, a depth reference must be taken on the dura with the tip of the relay lens.

1. Place the microscope above the prepared animal subject. Lower the system into the craniotomy hole, so that the tip of the rod lens is touching but not penetrating the dura.
 - Given the size of the cannula, this tip can be difficult to see. A mirror or a camera can be helpful to see exactly when the extremity of the lens touches the brain.
2. When the reference point is found, note it and elevate the microscope.
3. Carefully remove the dura from the reference point. A clean dura without any bleeding will allow optimal image quality while lowering the rod lens.

Type-L Cannula Implantation

From the beginning to the end of the implantation, handle the imaging cannula with care. The relay lens is very fragile and any stain or scratch can affect the image quality.

1. Connect the *Fluorescence Microscope Holder* to the illumination system.
2. Slowly lower the rod lens (around 1 $\mu\text{m/s}$) to allow proper tissue penetration (Fig. 2.7a).
 - The fluorescence microscope holder allows illumination during the penetration of the lens.
 - If the cannula is implanted when a sufficient viral expression has been reached, a diffuse fluorescence signal will confirm the positioning of the lens in the targeted area (e.g. injection site).
 - If the cannula is implanted immediately after the viral injection, the fluorescence signal cannot be used to confirm the positioning of the lens in the targeted site.
3. If the imaging cannula is not in the fluorescent area, it is possible to make another descent to reposition the lens.
4. If there is a significant gap between the *Protrusion Adjustment Ring* and the skull (Fig. 2.7b)
 - Verify that the *Fluorescence Microscope Holder* is secure and that the microscope will not move if touched.
 - Slowly unscrew the protrusion adjustment ring to bring it closer to the skull. Stop unscrewing if the **Rod Lens** starts moving inside the brain.

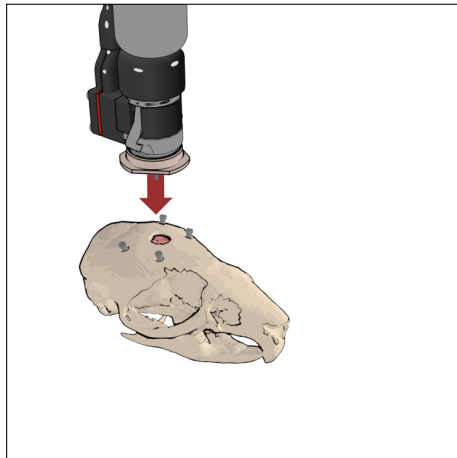

(a) Position the microscope on the skull, lower the lens slowly.

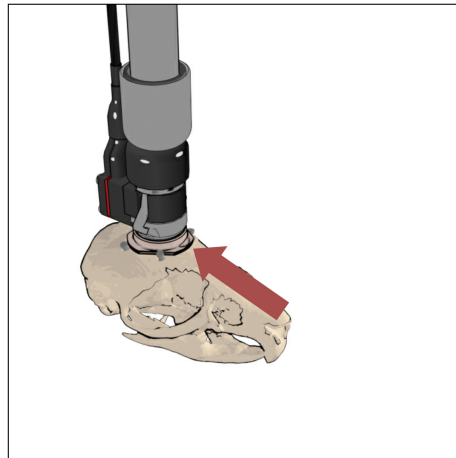

(b) Evaluate distance between skull and protrusion adjustment ring, adjust if necessary.

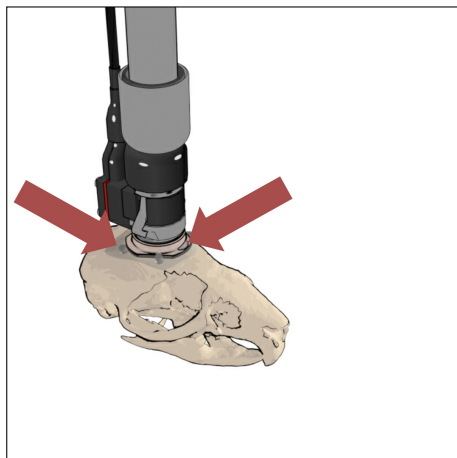

(c) Use fast drying glue to secure the protrusion adjustment ring on the skull.

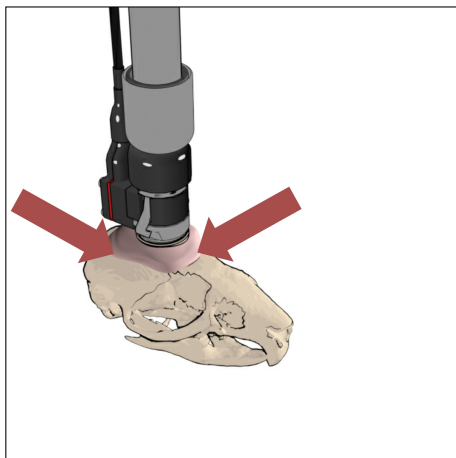

(d) Use dental cement to secure the protrusion adjustment ring on the skull.

Figure 2.7: Imaging Cannula Implantation Procedure

2.6 Securing the Cannula on the Skull

Once a cannula is in place it is necessary to secure it and the protrusion adjustment ring onto the skull. This part of the procedure is identical for both model-L and model-S microscopes.

1. Put fast drying glue between the *Protrusion Adjustment Ring* and the skull (Fig. 2.7c)³. If the ring is near the bones, the capillary action of a strong adherence liquid glue will ensure that the glue will pass below the ring. Otherwise, a gel glue should be used to fill the gap.
2. To improve the support of the screws in the holes, it is recommended to put glue on them.
3. When the glue on the surface of the skull is completely dried, secure the microscope to the skull by applying dental cement on the *Protrusion Adjustment Ring* and on the screws (Fig. 2.7d)⁴.
 - If the protrusion adjustment ring is not touching the skull, it is important to put some cement on the glue between the ring and the bones to stabilize the system.
 - The **Microscope Clamps** must remain free of cement to be able to separate the microscope and the cannula.
 - Tissues, muscles, skin or fur should not come in contact with the dental cement to enhance the adhesion of the microscope on the skull.
4. Once the dental cement has completely dried, the microscope can be removed.
5. Ensure that the **Microscope Barrel** is slightly loose. This ensures that the clamps are tight and will unsnap from the cannula in a single motion.
6. Unclip the cannula clamps using the snapping tool (Fig. 2.8a).
7. Remove the microscope from the imaging cannula (Fig. 2.8b).
8. Place the **Input Protective Cap** onto the implanted cannula to protect the rod lens (Fig. 2.8c).
9. Place the protective cannula onto the microscope to protect it (Fig. 2.8d).
 - If the imaging sessions will be done in a head-fixed configuration, the *Microscope Body* can be left attached to the *Fluorescence Microscope Holder* until the first imaging session.
 - For freely-moving experiments, unscrew the *Fluorescence Microscope Holder* and put its protective M3 cap to protect the optical pathway of the *Microscope Body*.

2.7 Animal Clamping and Unclamping

Due to the sensitivity of animal subjects, additional emphasis must be put on proper procedure to minimize pressure on the subject while placing and removing the microscope.

2.7.1 Clamping

1. After removing the protective cannula, place the barrel at the resistance point. Add 1/4 turn clockwise. This reduces tension on the **Microscope Clamps**, letting them hang more loosely.
2. Place the microscope onto the implanted cannula.
3. Gently push the **Microscope Clamps** under the **Cannula Clamp Groove**.
4. Gently unscrew the barrel to the resistance point. This will tighten the **Microscope Clamps** without requiring the force needed to push the **Microscope Clamps** into the **Cannula Clamp Groove**.

³Glue not provided with microscope.

⁴Dental cement not provided with microscope.

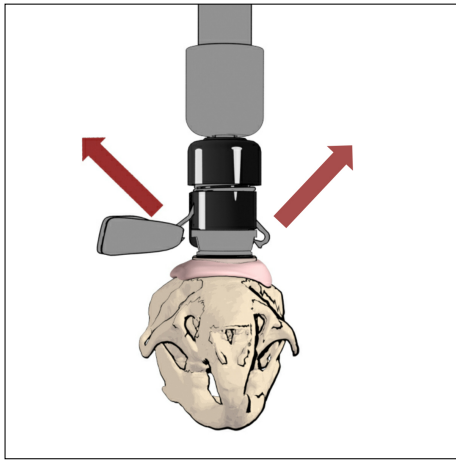

(a) Remove the clamps using the snapping tool.

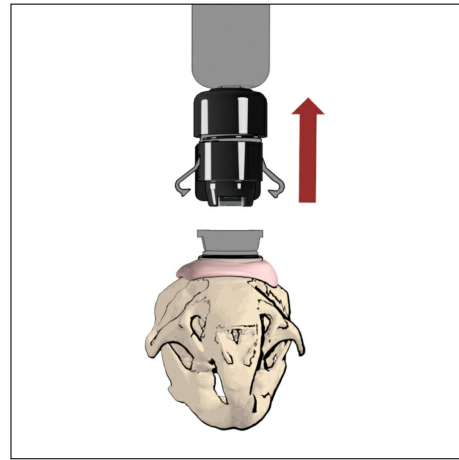

(b) Remove the microscope body.

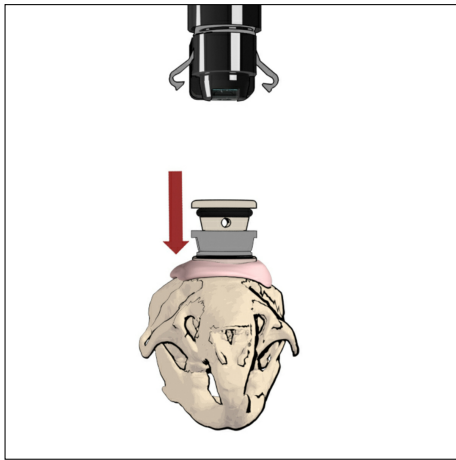

(c) Place the input protective cap on the imaging cannula.

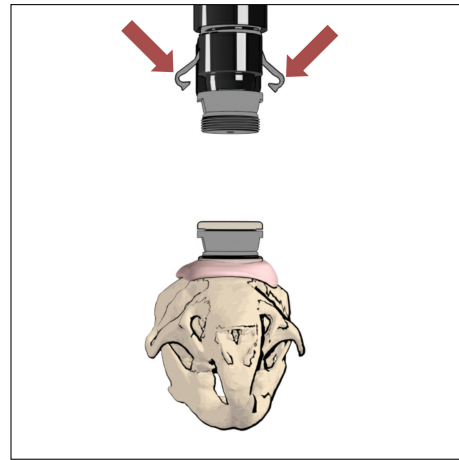

(d) Place the protective cannula on the microscope.

Figure 2.8: Microscope Removal

2.7.2 Unclamping

1. Ensure that the barrel is slightly loose. This ensures that the clamps are tight, and will unclip from the cannula in a single motion.
2. Unclip the **Microscope Clamps** using the *Snapping Tool* (Fig. 2.8a).
3. Remove the microscope from the imaging cannula (Fig. 2.8b).
4. Place the **Input Protective Cap** onto the implanted cannula to protect the rod lens (Fig. 2.8c).
5. Place the protective cannula on the microscope (Fig. 2.8d).

2.8 Tissue Healing and Training of the Animal (3 weeks or more)

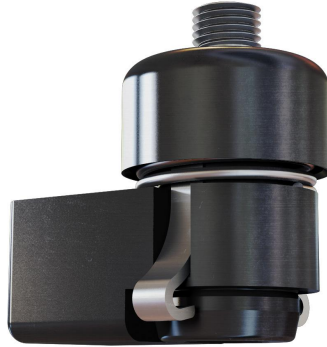

Figure 2.9: *Dummy Mmicroscope*

Usually, the system can distinguish cells 2 or 3 weeks after the implantation of the cannula. Nonetheless, better image quality is obtained 2-8 weeks after the implantation. The waiting time for tissue repair can be a good period to use the *Dummy Microscope* (Fig. 2.9). It is important to train the animal to tolerate the weight of the microscope on its head and to get used to moving easily in his cage with the disposal.

Imaging Sessions

The following section describes the basics of an imaging session using the *Single-color Miniature Fluorescence Microscope*.

1. Prepare the microscope for a head-fixed configuration, as described in section 2.2.
2. Before installing the microscope, place the anesthetized subject in a stereotaxic head restraint.
3. Remove the **Input Protective Cap** from the cannula.
4. Install the microscope in the cannula. The stereotaxic head restraint decreases the pressure applied on the head of the animal when the microscope body is secured in the implanted cannula.
5. If performing a head-fixed experiment, complete the connections of the system (Fig. 3.1a) and open the acquisition system. This allows imaging of the region of interest.
6. If performing a freely-moving experiment (Fig. 3.1b), remove the animal from the stereotaxic apparatus and let the animal recover from the anesthesia.
 - During behavior imaging sessions, it is recommended to put the metal shield at the base of the ultralight cable to protect it from animal interference, such as chewing or scratching.
7. For more details about the connections of the system and the use of the Doric Neuroscience Studio Software, see the [Single-color microscope manual](#).

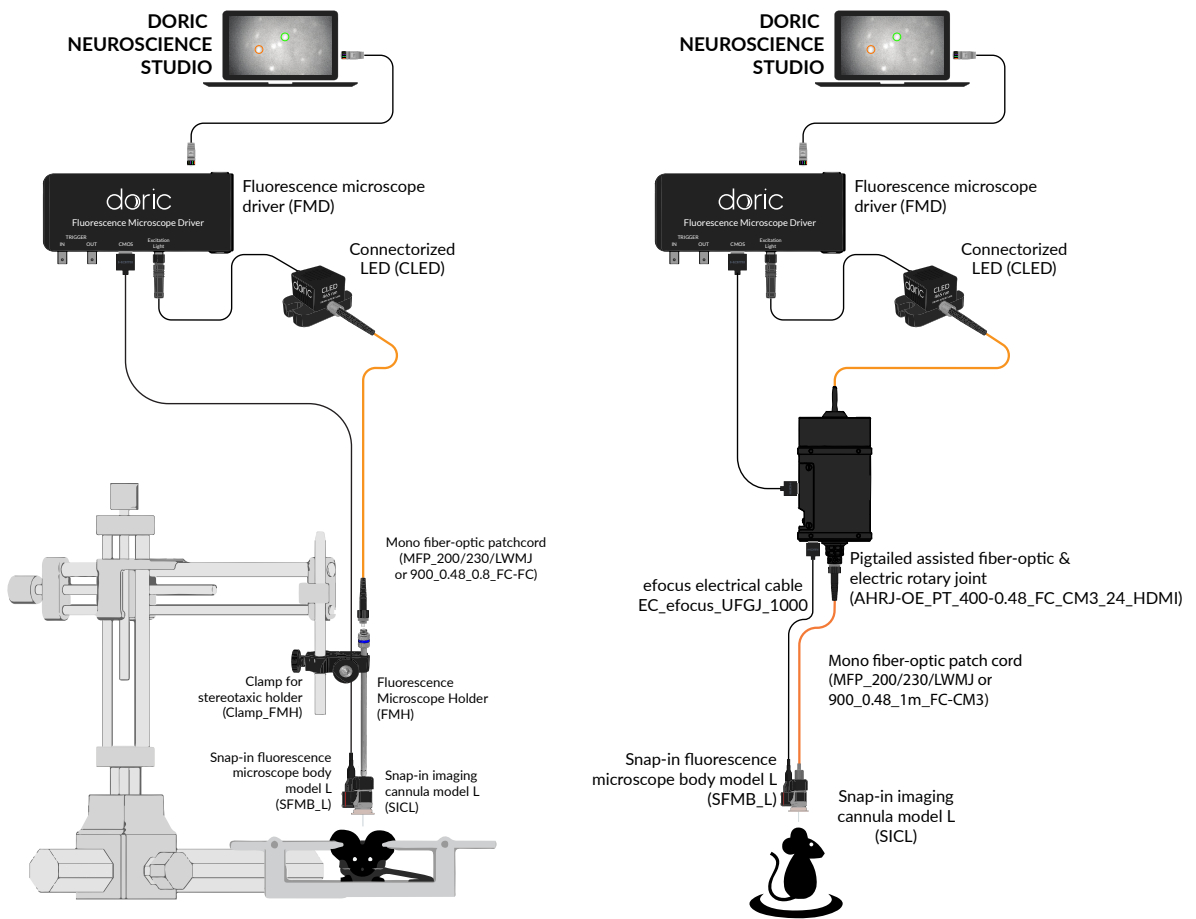

(a) Head-fixed Configuration for Deep-brain Imaging of GCaMP6.

(b) Freely-moving Configuration for Deep-brain Imaging of GCaMP6.

Figure 3.1: Single-color Microscope System Configurations

Handling & Cleaning

4.1 Important handling information



WARNING : Handle the microscope and the cannula with care.



Miniature fluorescence microscopes are composed of sensitive electronic components and should always be handled with care. When they are not used, the microscope body with its cannula should be stored in a closed, dust-free environment. Some microscope components must be handled with extra care:

- **Electrical cable: Do not twist or pull on the cable.** This cable is pigtailed to the CMOS sensor and cannot be easily replaced.
- **Relay lens:** The cannula lens is made of glass and is unprotected. **Abrasive materials can scratch the surface** and reduce the image quality.

The microscope bodies and the cannula lenses are made of glass, metal, plastic and the contact with organic tissues or liquids, like blood or saline solution is not recommended. While the cannula is designed to be in contact with such substances, the microscope body is not. If the body comes in contact with these substances, clean the optics (section 4.2) to avoid the appearance of stains.

4.2 Cleaning optics

The microscope objective lens should be cleaned before each use. The procedure explained here can also be used to clean the cannula relay lenses.

- Turn the driver OFF.
- **Wear gloves to manipulate the microscope.** Finger oil can stain the glass and is often difficult to remove properly.
- Use isopropyl alcohol on a cotton swab to gently clean the lens.
- **Do not blow on the optics.** Saliva particles will often stain the surface. Larger dust particles can be removed using a dust-free blower before cleaning with a cotton swab.

4.3 Imaging cannulas reuse

The implanted cannulas are sold as disposable but can be re-used if removed carefully. To do so, simply remove the glued protrusion adjustment ring from the metal part. In this case, plan spare sets of protrusion adjustment rings. Acetone can be used to clean the cannula lens with a cotton swab (never dip the cannula in acetone), but care should be taken not to expose the binding site between the lens and the metal part of the cannula.

5.1 Contact us

For any questions or comments, do not hesitate to contact us by:

Phone 1-418-877-5600

Email sales@doriclenses.com

The logo for Doric Lenses, featuring the word "doric" in a lowercase, sans-serif font. The letter 'o' is stylized with a white highlight on its left side, giving it a three-dimensional appearance.

© 2022 DORIC LENSES INC

357 rue Franquet - Quebec, (Quebec)
G1P 4N7, Canada

Phone: 1-418-877-5600 - Fax: 1-418-877-1008

www.doriclenses.com