

	8	7	6	5	4	3	2	1	
	R	CC	A2	A4	A6	A8	A10	C.A.	NOTES
S1	-0.4855	-0.45	0	-5.32e-2	6.234e-1	-3.122	1.6449e1		
S2	Plano								

$$Y = \frac{\frac{1}{R}x^2}{1 + \sqrt{1 - \frac{(K+1)x^2}{R^2}}} + A_4x^4 + A_6x^6 + A_8x^8 + A_{10}x^{10}$$

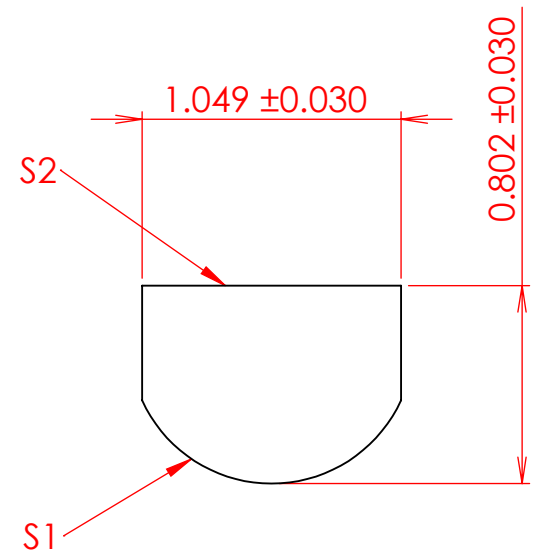
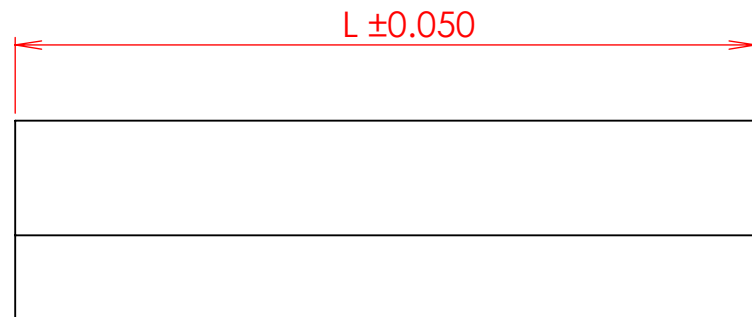

Notes:

- Design wavelength: 808 nm
- EFL = 0.590 mm
- WD = 0.150 mm
- Surface S1 and S2:
Quality: Scr/Dig: 40-20
Irregularity: S1: P-V = 1 micron over C.A
S2: lambda/4 over C.A
- All the other surfaces fine ground (600 grit).
- Centering tolerance: Tilt < 0.25 deg
- Focal length tolerance: ± 3%

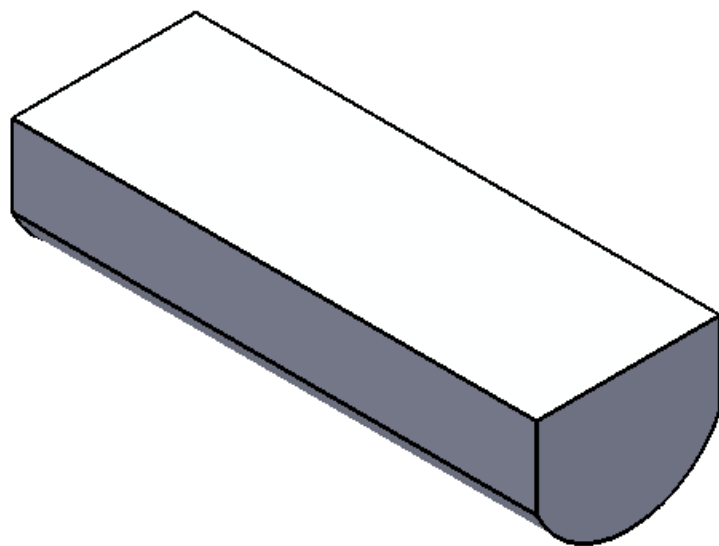

PROPRIETARY AND CONFIDENTIAL
THE INFORMATION CONTAINED IN THIS DRAWING IS THE SOLE PROPERTY OF Doric Lenses Inc.. ANY REPRODUCTION IN PART OR AS A WHOLE WITHOUT THE WRITTEN PERMISSION OF Doric Lenses Inc. IS PROHIBITED.

UNLESS OTHERWISE SPECIFIED:		NAME	DATE
DIMENSIONS ARE IN MM		DRAWN	
ANGULAR: ± 0.25 deg		CHECKED	
ONE PLACE DECIMAL ±0.1		ENG APPR.	
TWO PLACE DECIMAL ±0.05		MFG APPR.	
THREE PLACE DECIMAL ±0.005		Q.A.	
INTERPRET GEOMETRIC TOLERANCING PER:		Third angle projection:	
MATERIAL S-TiH53			
FINISH			
DO NOT SCALE DRAWING			

UNLESS OTHERWISE SPECIFIED:		NAME	DATE
DIMENSIONS ARE IN MM		DRAWN	
ANGULAR: ± 0.25 deg		CHECKED	
ONE PLACE DECIMAL ±0.1		ENG APPR.	
TWO PLACE DECIMAL ±0.05		MFG APPR.	
THREE PLACE DECIMAL ±0.005		Q.A.	
INTERPRET GEOMETRIC TOLERANCING PER:		Third angle projection:	
MATERIAL S-TiH53			
FINISH			
DO NOT SCALE DRAWING			

doric 357 rue Franquet, Quebec, QC G1P 4N7, Canada, Tel: 418 877 5600	
TITLE: ACL_PCX_INF_S-TiH53_0.590(L)	
SIZE B	DWG. NO. D141-0362
SCALE: 10:1	WEIGHT:
REV 01	SHEET 1 OF 1